

HENEMAQ S. DE R.L. DE C.V.
HENESA S. DE R. L. DE C.V.



DAVID GUZMAN 112, CD. INDUSTRIAL, C.P. 20290
AGUASCALIENTES, AGS. MEXICO



ventas @henesa.com.mx
ventas @henemaq.com.mx

HENESA - HENEMAQ

Consortio de maquinado industrial, diseño y fabricación de dispositivos, calibradores, refacciones, soldadura y servicios industriales de alta calidad.

HENEMAQ

MISIÓN

Diseñar, fabricar y ofrecer servicios de calidad, trabajando enfocados en cumplir las expectativas de nuestros clientes, trabajando en equipo y fomentando la mejora continua.

VISIÓN

Ser una empresa reconocida por nuestros clientes, por la calidad de sus productos o servicios, integrando objetivos y metas de nuestros clientes, con trabajo en equipo.

ISO 9001 : 2015

2024...



NUESTROS SERVICIOS

- **DISEÑO**
- **CORTE LASER**
- **DOBLEZ CNC**
- **PAILERIA Y SOLDADURA**
- **LIMPIEZA DE PINTURA POR PIROLISIS**
- **FABRICACION Y MANTENIMIENTO A JIGS**
- **MAQUINADO**
- **LINEA DE PINTURA ELECTROSTATICA**
- **FABRICACION DE FUNDAS ANTIESTATICAS DE ROBOT**



DISEÑO INDUSTRIAL

Ofrecemos a nuestros clientes soluciones objetivas e innovadoras, capaces de satisfacer íntegramente las necesidades de la industria. Así mismo, desarrollamos alternativas en las respuestas de conflictos técnico-tecnológicos equilibrando el beneficio entre la industria y el medio ambiente. Buscamos la optimización en la creación de mecanismos y sistemas complejos.

- Modelado y simulación de moldes.
- Análisis por elemento finito.
- Fabricación rápida de prototipos.
- Generación y simulación de programas de control numérico.
- Planificación de procesos.
- Diseño de herramientas.

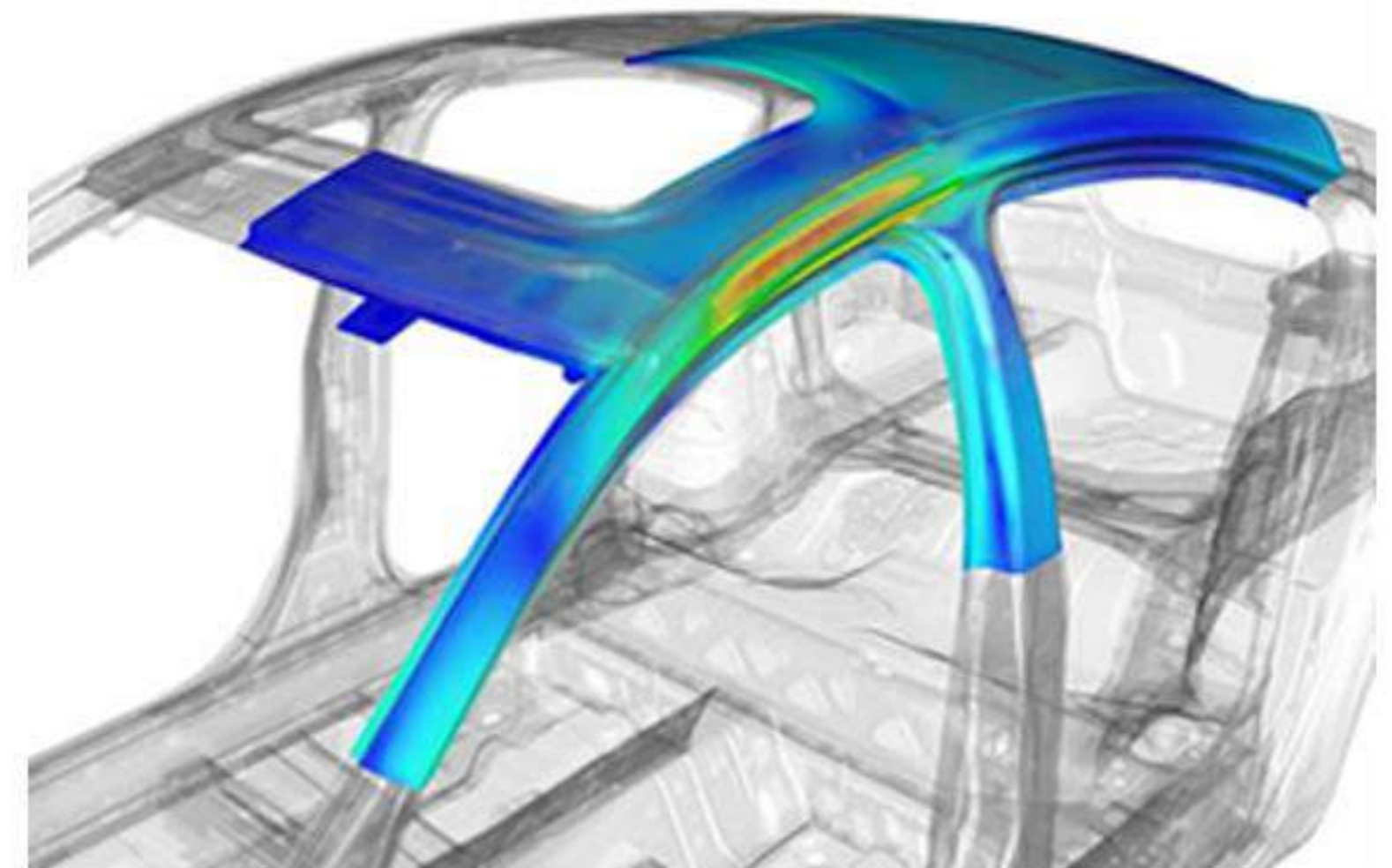

BACKGROUND



SERVICIOS DE MAQUINADO

- **MAQUINADO CNC**
EQUIPOS DE CONTROL NUMÉRICO
COMPUTARIZADO (CNC)
- **ELECTRO-EROSIONADO**
EN EQUIPO DE EROSIÓN POR PENETRACIÓN
- **RECTIFICADO**
-EN EQUIPO DE RECTIFICADO DE SUPERFICIES
PLANAS
- **EQUIPOS DE TORNEADO**
-EN EQUIPO DE TORNEADO
- **EQUIPOS DE FRESADO**
-EN EQUIPO DE FRESADO



SERVICIOS DE MAQUINADO

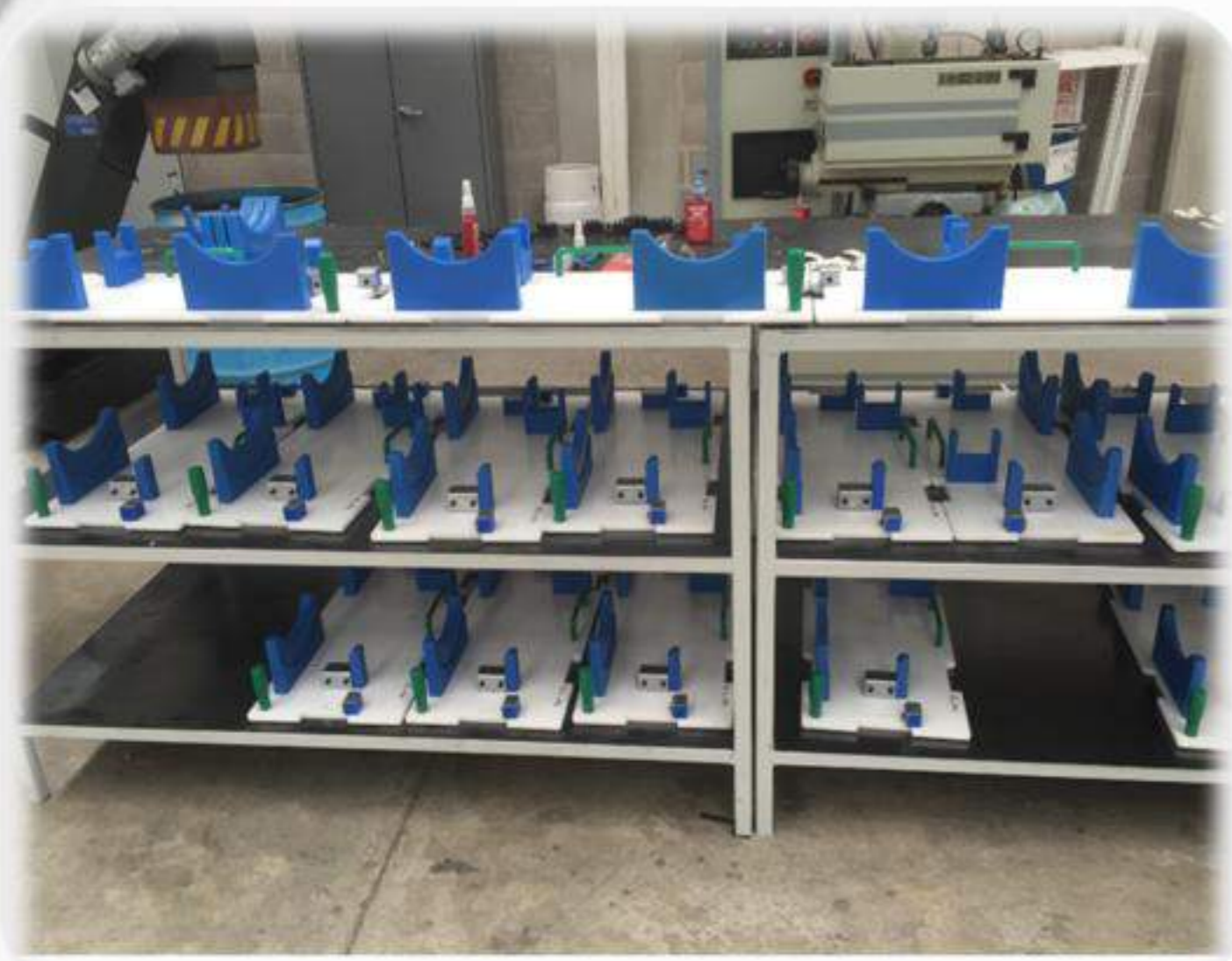
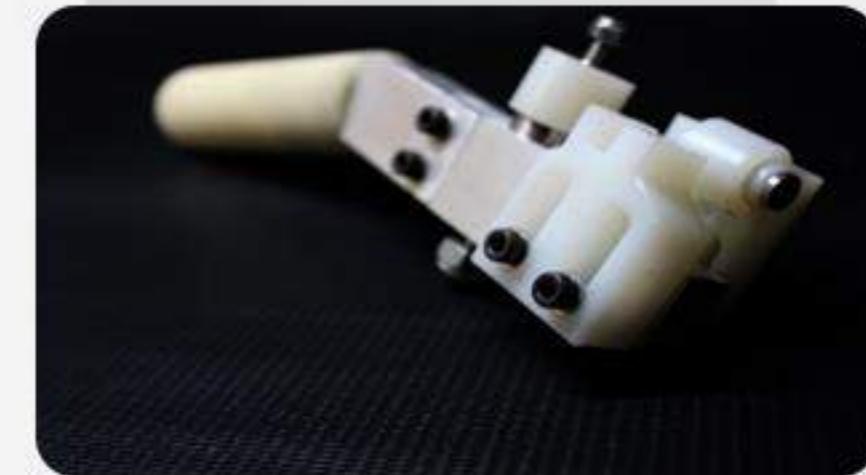

OTROS SERVICIOS



FABRICACIÓN Y DISEÑO DE CELDAS OPERATIVAS

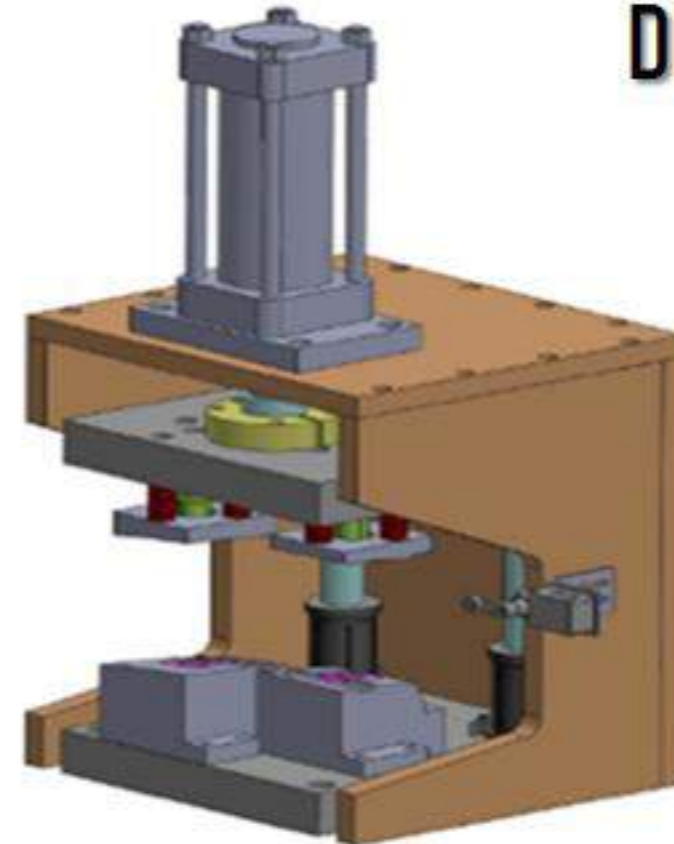
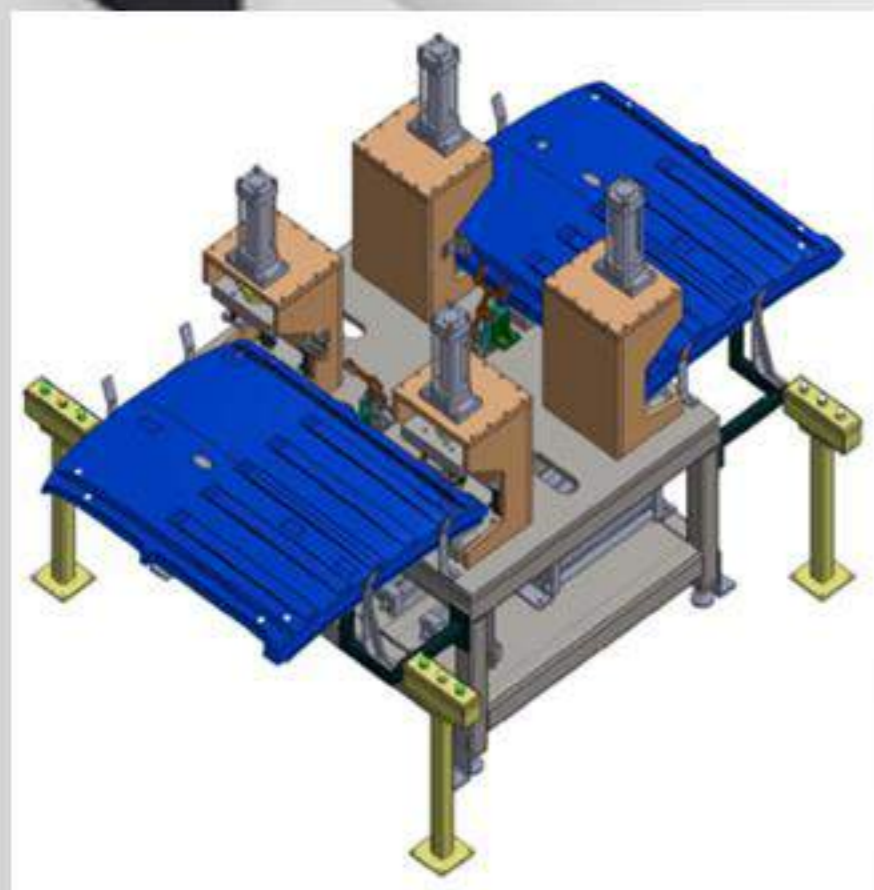
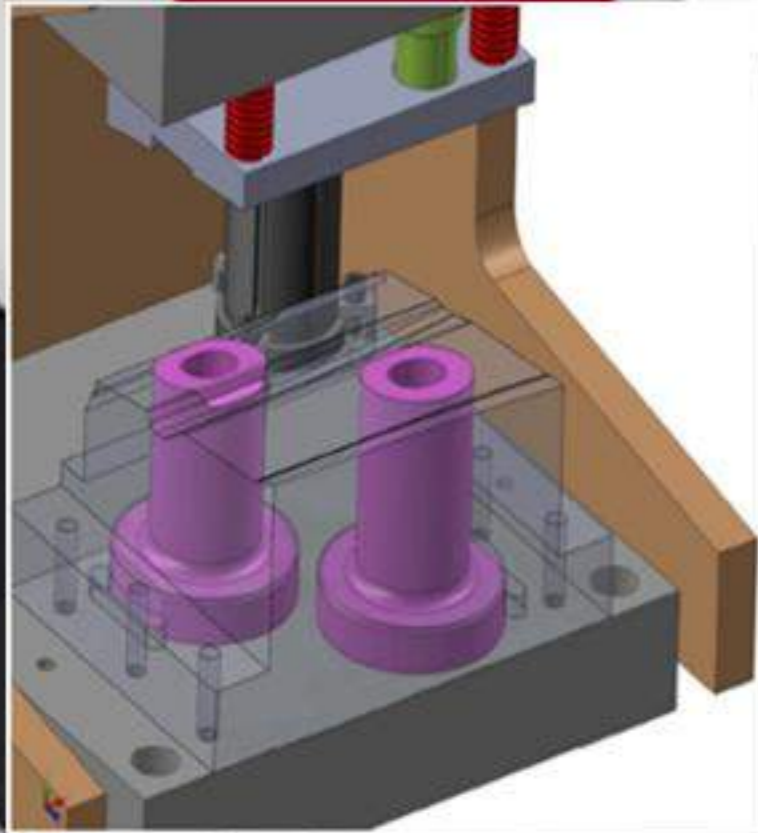

DISEÑO Y FABRICACIÓN DE MESA DE PUNZONADO DE ROOF PICK UP DOBLE CABINA



DISEÑO, FABRICACION Y MANTENIMIENTO A JIGS



- Diseño
- Fabricación
- Limpieza a jigs saturados de pintura:
- Proceso térmico y químico desde un tornillo M3, hasta un Dolly para mover un vehículo.
- Reparación, cambio de partes, mejora de diseños, recuperación con soldadura e inspección de partes.

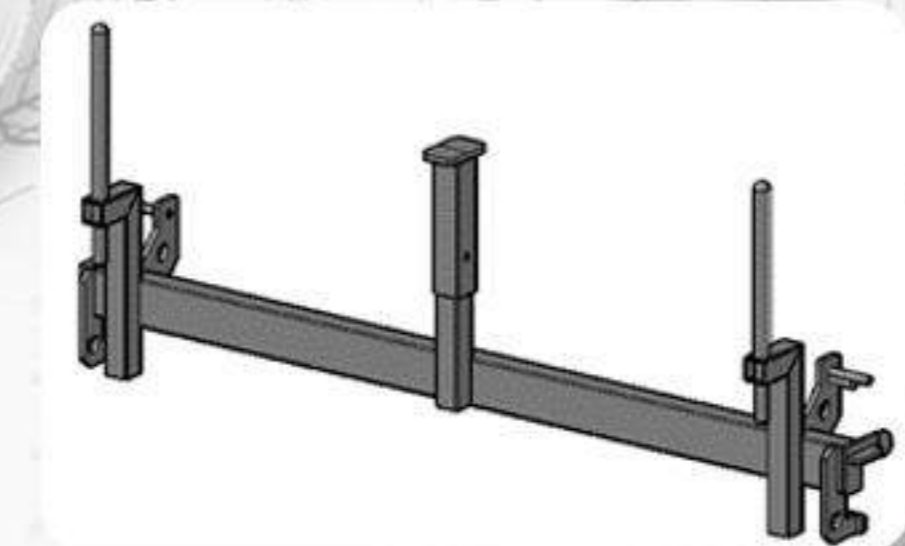
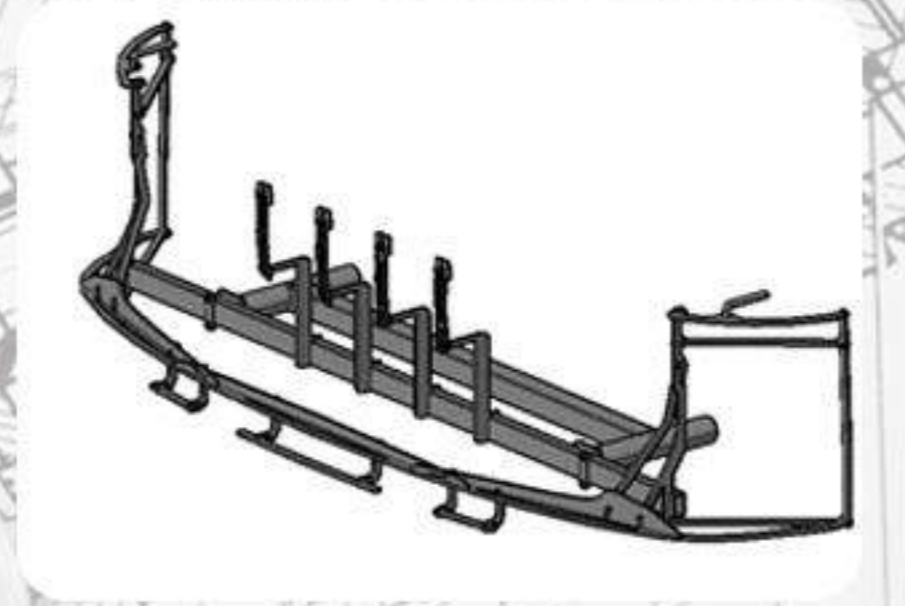



FABRICACION DE ESTRUCTURAS Y DOLLIES

ESTRUCTURA PARA PANELES DE CONTROL

FABRICACION DE DOLLY PARA
SUBENSAMBLE DE MOTOR

RACK PARA TUBERIA





FABRICACION DE TRANSPORTADORES DE RODILLO





FABRICACIÓN DE PLATAFORMAS INDUSTRIALES CON RECUBRIMIENTO DE ACERO INOXIDABLE





FABRICACIÓN DE GUARDAS Y PROTECCIONES

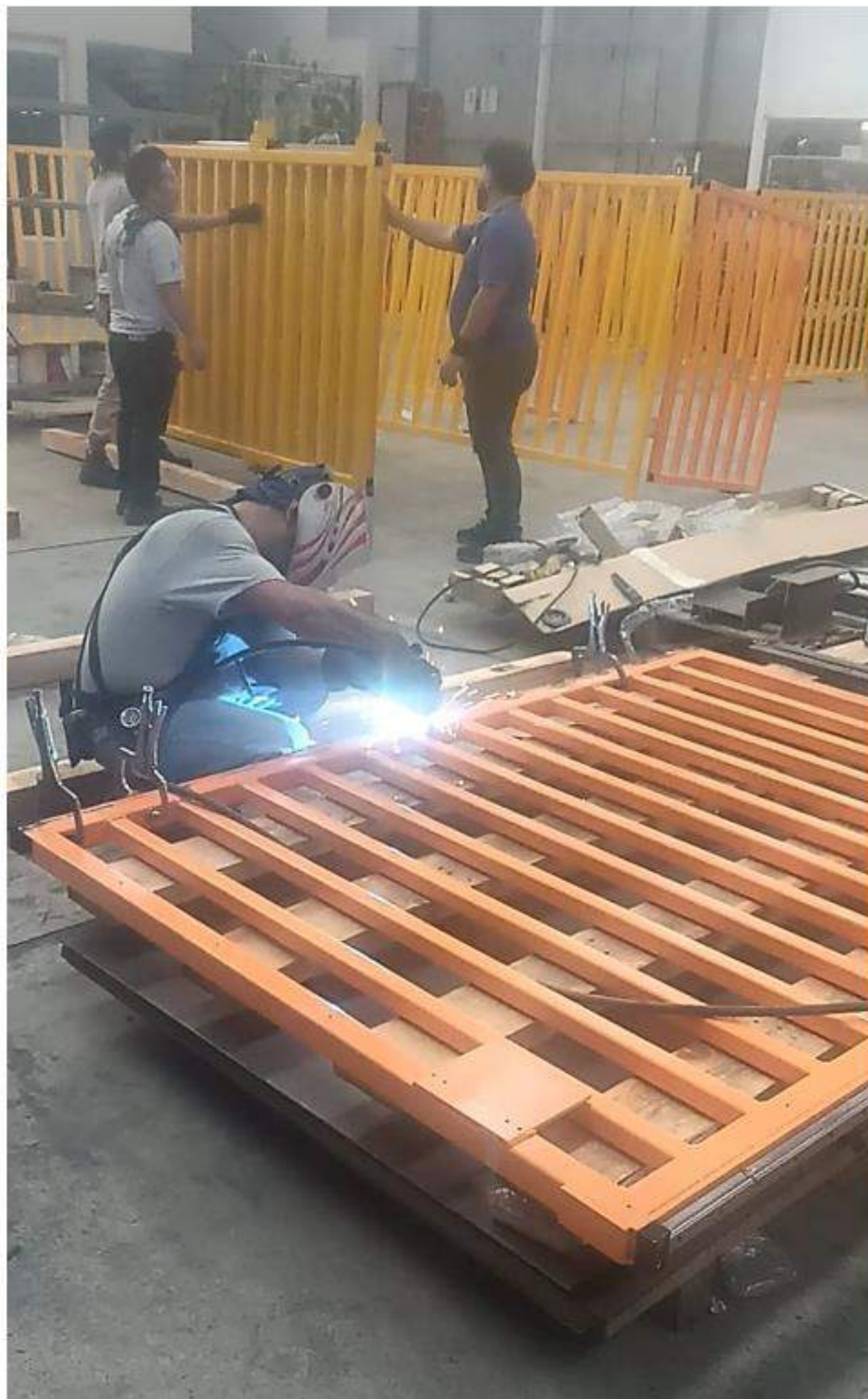



FABRICACION ESPECIAL DE TORRES SUNROOF, DEACUERDO A NECESIDAD DEL CLIENTE

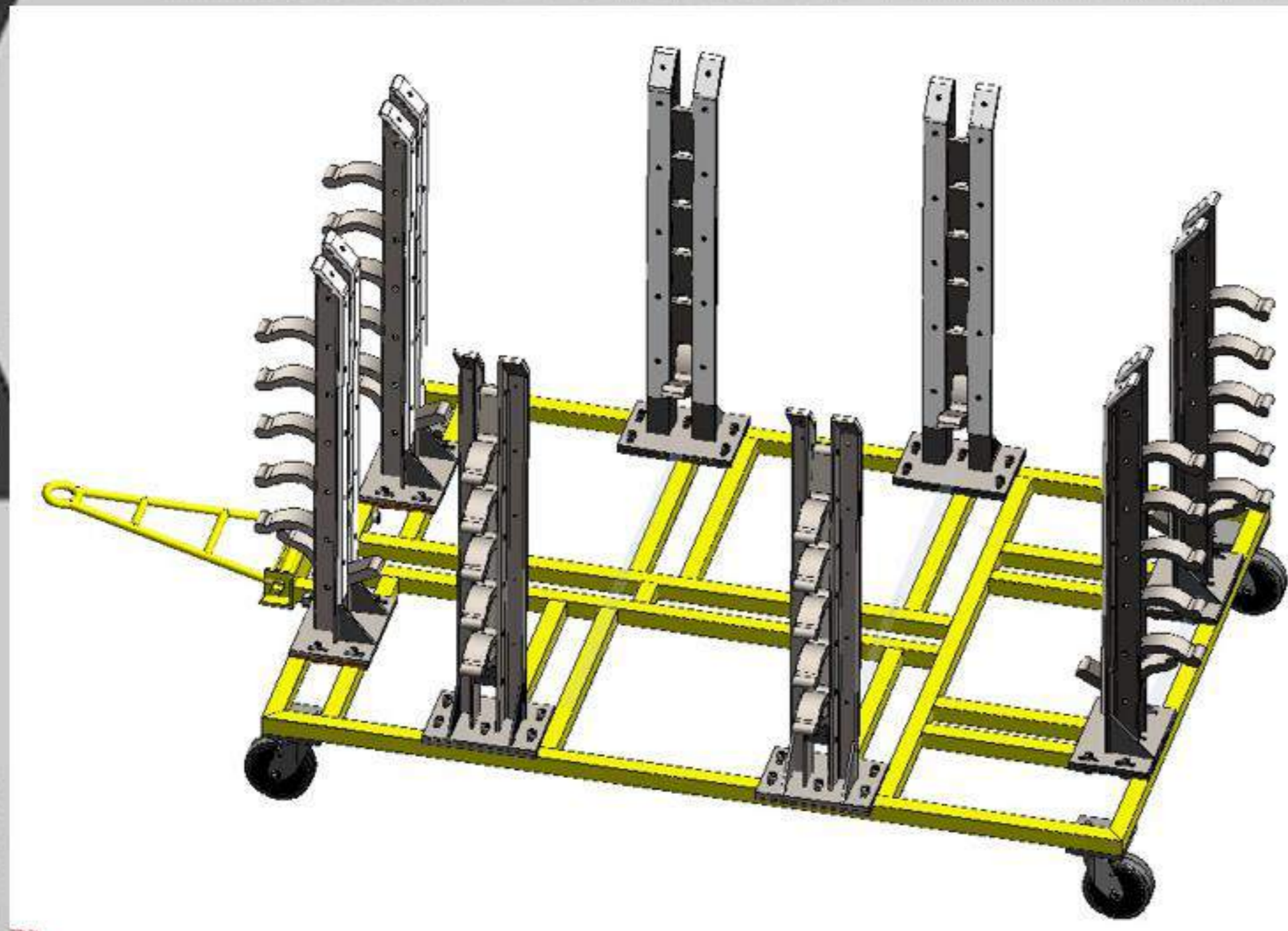



FABRICACION DE ANC DOLLYES

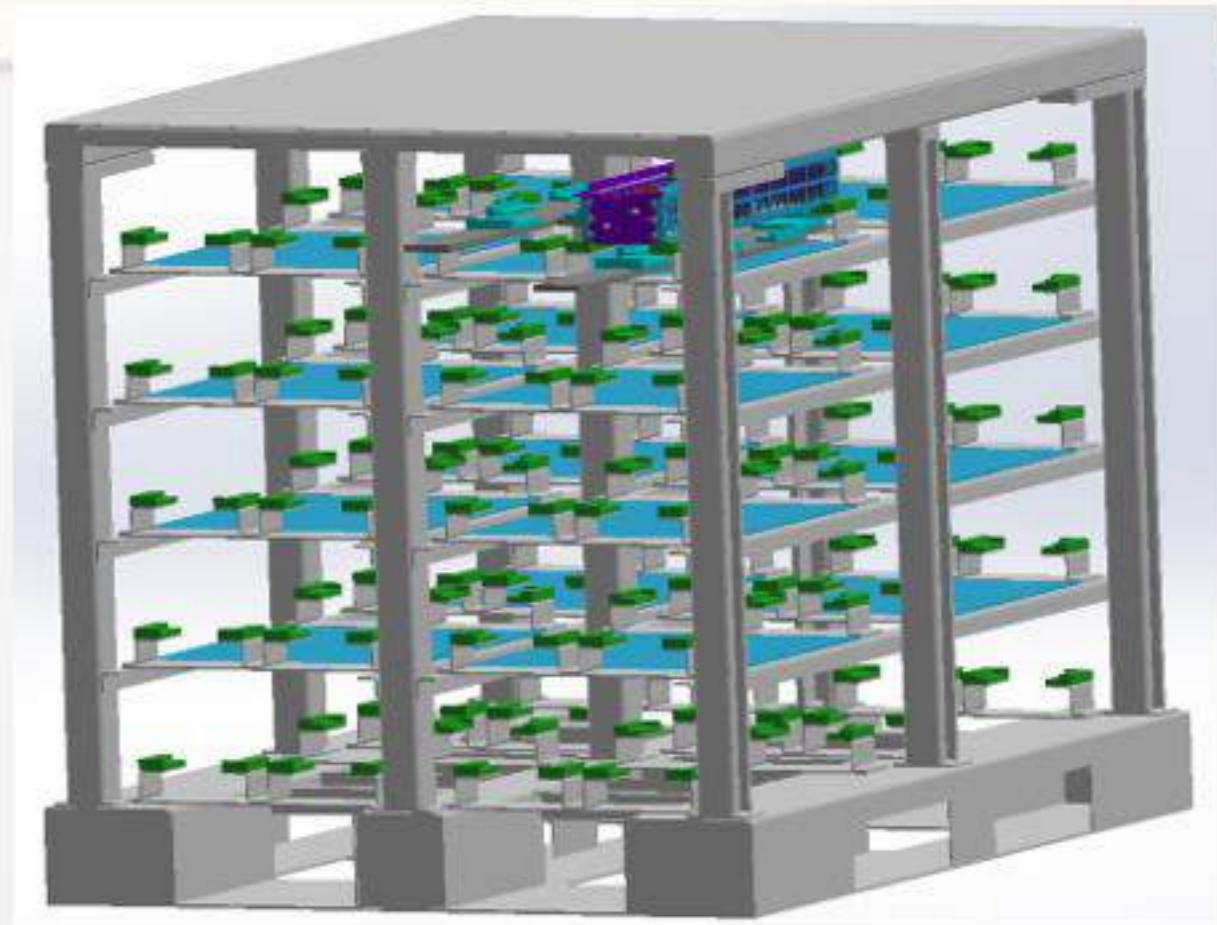



FABRICACION DE COMP CART

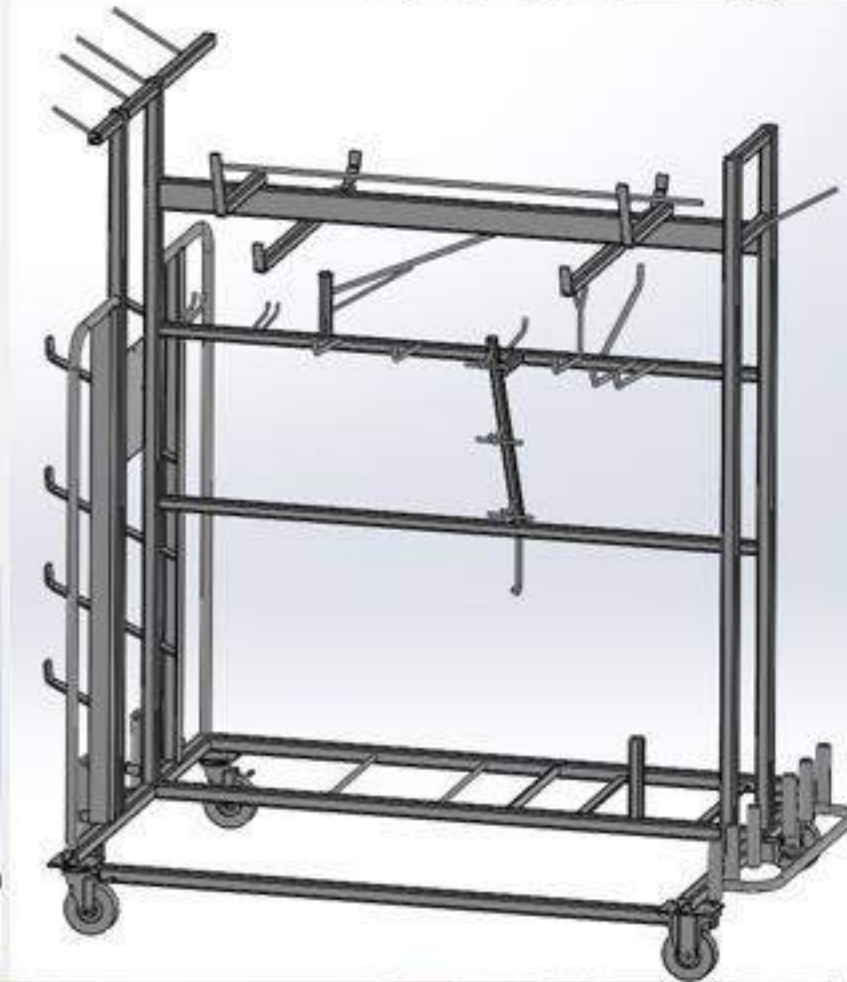
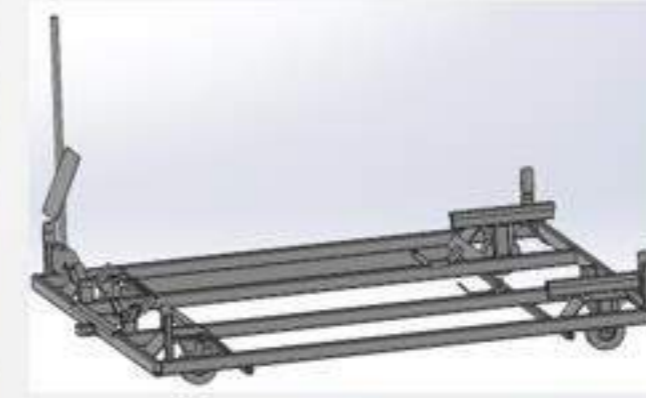



FABRICACION DE GAUGES

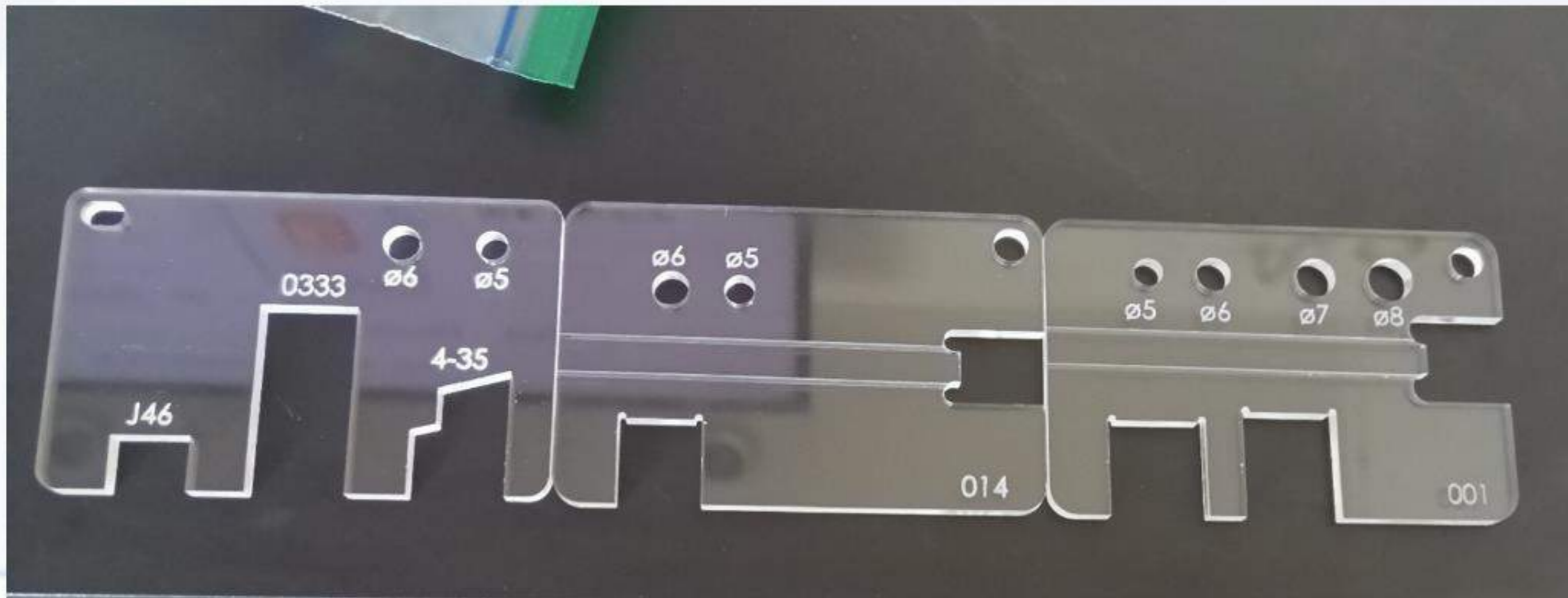
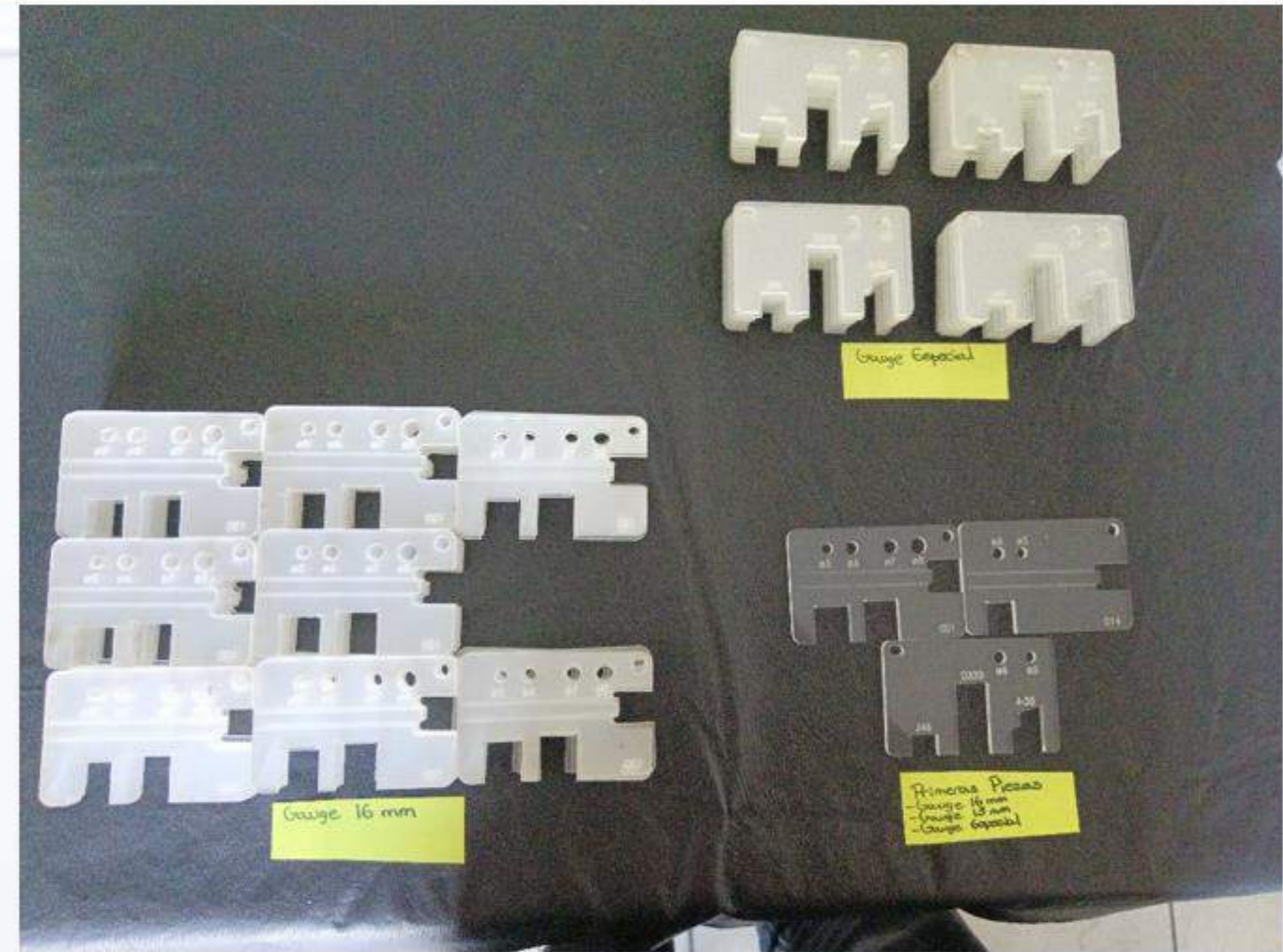



PAILERÍA Y SOLDADURA

- **EQUIPOS PARA SOLDADURA OXIACETILENO**
- **EQUIPOS PARA SOLDADURA MILLERMATIC 212
(MICRO ALAMBRE)**
- **EQUIPOS PARA SOLDADURA MILLERMATIC 210
(MICRO ALAMBRE)**
- **EQUIPOS PARA SOLDADURA INFRA M12-300**
- **PUNTEADORA RAYOMEX 15KVA**
- **EQUIPOS PARA SOLDADURA INFRA MI-225L**
- **HORNO T. TERMICO KRESS C100-6B**
- **EQUIPO DE SAND BLAST**





- Estructura base de CPA y extracción de polvos (mist colecto)
- Case Trabajos de acero inoxidable
- Estructura para dollyes para AGV



CORTE LASER



- EQUIPO DE CORTE LASER TRUMPF 1030 2000 W**

TruLaser 1030 cuenta con una capacidad de 2000 wats de potencia cortando espesores de .5 mm hasta 16 mm en acero al carbón, de .5 mm a 5 mm en aluminio y acero inoxidable; la mesa de corte mide 3600 mm x 1600 mm, para generar el corte contamos con los siguientes tipos de gas: aire, oxigeno y nitrógeno.



DOBLEZ CNC



- **EQUIPO DE DOBLEZ TRUBEND 3100 TRUMPF**
- TruBend 3100 cuenta con una fuerza de presión de 110 toneladas y 118 pulgadas de longitud de plegado en un diseño que ahorra espacio. Viene de serie con un tope trasero de 2 ejes, con la opción de expandirse a un tope trasero de 4 o 5 ejes, lo que hace posible doblar piezas con precisión, incluso cuando se trata de geometrías complejas de piezas. Según el fabricante, la máquina es apta para entrar en el doblado de precisión.



LIMPIEZA DE PINTURA POR PIROLISIS



¿Qué es la pirolisis? Se trata de una función que descompone los restos de suciedad en piezas y dispositivos, como grasas y pintura a altas temperaturas la materia orgánica se descompone en CO₂ y agua y se evapora, mientras que la materia inorgánica se convierte en cenizas.





FABRICACION Y SUMINISTRO DE FUNDAS ANTIESTATICAS DE ROBOT

PINTURA ELECTROSTATICA



PINTURA ELECTROSTATICA EN POLVO CON PROCESOS DE:

- Desengrase, fosfato y sello
 - Lavado y enjuague
-
- CABINA DE PINTURA ELECTROSTÁTICA CON TINA DE ASPERSIÓN
 - HORNO DE CURADO
 - TRANSPORTADOR VARIABLE CONTINUO
 - CABINA DE PINTURA ELECTROSTÁTICA EN POLVO





HENESA

*JUNTOS ALCANZAMOS
NUESTRAS METAS*

**POLITICA DE CALIDAD
En HENESA - HENEMAQ
PROVEEMOS A NUESTROS
CLIENTES, PRODUCTOS Y
SERVICIOS QUE CUMPLEN CON
LAS ESPECIFICACIONES,
APOYADOS SOBRE NUESTRA
CULTURA DE CALIDAD,
ESTANDARIZACIÓN, MEJORA
CONTINUA, MEDIO AMBIENTE,
SALUD Y SEGURIDAD.**

PRICIPALES CLIENTES



COMPAS 2000279

MAZDA KFQ32

NISSAN MX0122577

BMW 250673-10

MARELLI 30431

K & S ARNESS

HEN0001684MN

TOYOTA MOTOR
AN01433800661

SRG GLOBAL C0510062

TOYOTA TSUSHO 123-
HENESA S. DE R.L. DE C.V.

HENESA

JUNTOS ALCANZAMOS
NUESTRAS METAS



CONTACTO



VENTAS: 449 9805594
TELEFONO FIJO: 449 200 96 96



ventas @henesa.com.mx
ventas @henemaq.com.mx



DAVID GUZMÁN HERNÁNDEZ #112
COL. CIUDAD INDUSTRIAL

ISO 9001 : 2015

2024...

